



Available on CylindersNow SQUARE HEAD CYLINDERS -150 PSI PNEUMATIC TO 3000 PSI HYDRAULIC

OFFERED FOR EITHER OR BOTH ENDS OF CYLINDER

SEVERAL SWITCH SERIES AVAILABLE, OR ACTUATOR ONLY, TO OPERATE YOUR OWN SIGNAL DEVICE

#### **L SERIES - Basic Actuator**

The actuator is operated through the action of a hardened cam which is similar to a cushion piston. When the cylinder is cushioned, the cam also performs the function of the cushion piston. The cam contacts the actuator plunger approximately  $\frac{3}{16}$  inch from the end of stroke and moves the plunger and stem assembly about  $\frac{1}{16}$  inch. The action compresses the spring which returns the plunger and stem assembly when the stroke is reversed and cam disengagement takes place. A lighter force spring is employed for pneumatic cylinders and a heavier one for hydraulic. Shown in this Accessories Brochure on Page AC-2 is an illustration of an actuator in the head end of a cylinder. The hardened cam has not yet engaged the plunger. Operation of an actuator in the cap end of a cylinder is similar except the cam is an extension of the piston rod as is employed in a cushioned rear cylinder.

The **L Series** actuator is available for applications which require the mounting of a limit switch or signal device other than those described below. The customer-supplied device can be mounted by utilizing the  $\frac{3}{8}$ -18 UNF-2 threaded extension. A locking nut is provided. 180°F continuous temperature rating.

#### **LB and LD SERIES - Actuator with Switch and Junction Box**

The actuator is supplied with a limit switch enclosed by a junction box. The box is gasket sealed, making it dust proof and water tight. The cover is easily removed and removal provides easy access to the switch for removal or adjustment. Two  $\frac{1}{2}$  inch threaded ports, one on each side, provide for conduit connection. The box is retained by a lock nut and can be rotated up to 360° after installation.

The **LB Series** has a SPDT limit switch with an electrical rating of 15 amps at 125, 250 or 480 volts AC. It can be wired either normally open or normally closed.

The **LD Series** is similar to the LB series except the limit switch is DPDT 180°F continuous temperature rating.

#### **LS SERIES - Actuator with Sealed Switch**

The actuator is supplied with an adapter and a DPDT sealed switch. The switch is sealed to dust and moisture. It has six 72 inch long leads of No. 20 wire and has an electrical rating of 5 amps, 125 volts with a 180°F continuous temperature rating. Each wire is marked with circuit identification and wire gauge number.

The DPDT switch is housed in a one inch diameter enclosure and can be removed without disturbing the built-in actuator. Adjustment is easily accomplished by rotating the switch housing.

#### **LX SERIES**

The actuator is supplied with an installed mounting adapter and an explosion proof SPDT enclosed switch. The enclosed switch is UL approved for hazardous locations Class 1, Groups C and D and also Class 11, Groups E and G.

The switch is rated at 15 amps, 125, 250 or 480 volts AC:  $\frac{1}{8}$  HP-125 volts AC,  $\frac{1}{4}$  HP-250 volts AC. The switch is also rated at  $\frac{1}{2}$  amp at 125 volts DC and  $\frac{1}{4}$  amp at 250 volts DC.

#### **LA SERIES**

The actuator is supplied with an adapter bracket and a mini air valve which serves as an air limit switch. The valve functions as a normally open or a normally closed 2-way and as a normally open or a normally closed 3-way.

The valve is flow rated at 24 CFM with 100 psi inlet pressure. Ports are  $\frac{1}{8}$  inch NPT. Switch is rated for 200 psi.

The use of air limit switches offers the all-air control advantages of better reliability, more convenience, and less expense. Air limit switches replace both the electrical switches and solenoids.

## L SERIES

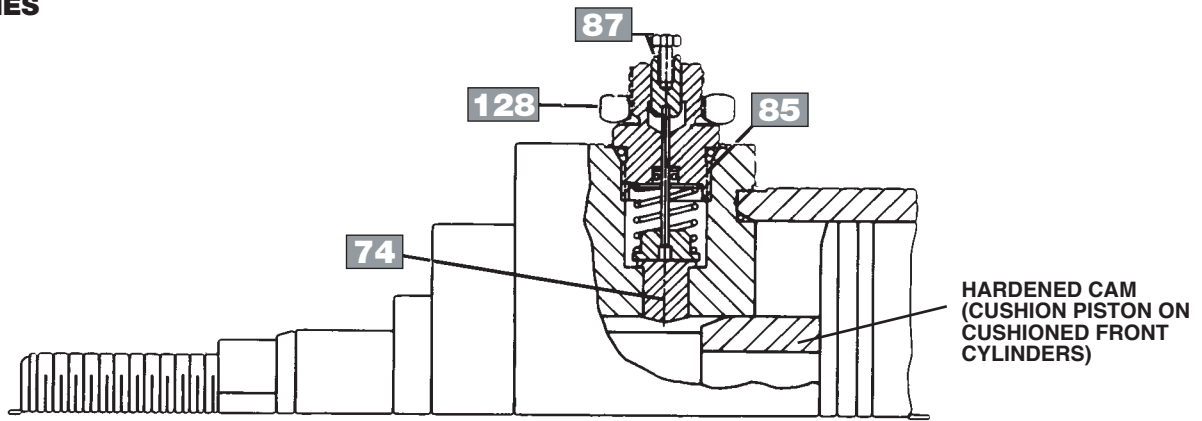

## LB SERIES

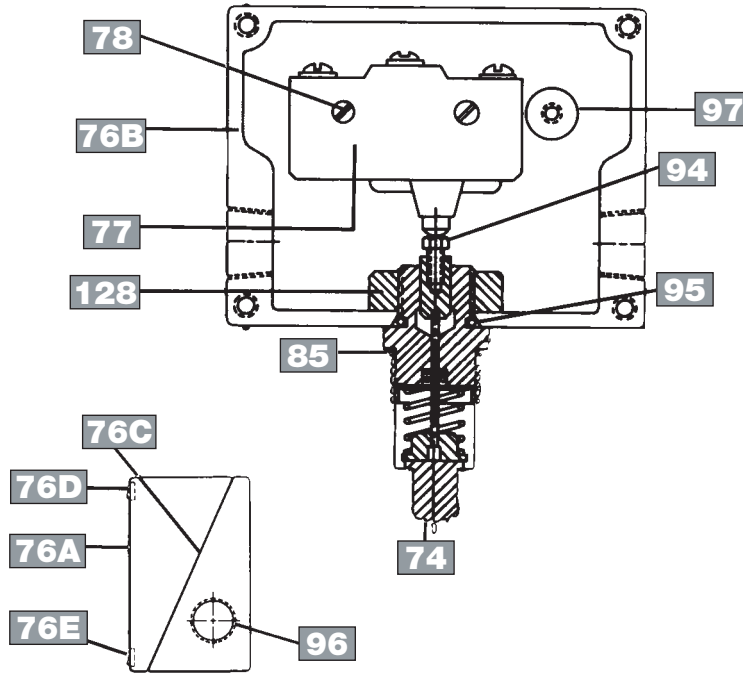

## LS SERIES

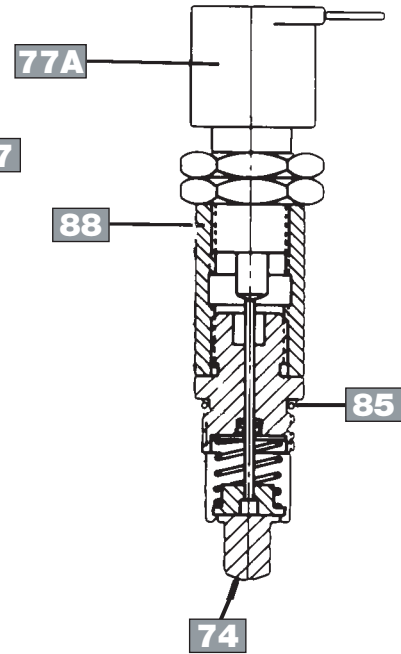

### Parts List

ITEM NUMBER	DESCRIPTION	NUMBER	QUANTITY REQUIRED
74	PLUNGER	*	1
76	JUNCTION BOX ASSEMBLY	*	1
76A	JUNCTION BOX COVER	*	1
76B	JUNCTION BOX	*	1
76C	GASKET	*	1
76D	COVER SCREW	*	2
76E	COVER SCREW	*	2
77	LIMIT SWITCH	*	1
77A	SWITCH	698-30002	1

ITEM NUMBER	DESCRIPTION	NUMBER	QUANTITY REQUIRED
78	LIMIT SW. MTG. SCREW	*	2
85	HOUSING SEAL	*	1
87	ACTUATOR ASSEMBLY	*	1
88	ADAPTER	698-54316	1
94	ADJUSTING SCREW	*	1
95	BOX SEAL	*	1
96	PLUG	*	1
97	GROUND SCREW	*	1
128	JAM NUT	698-30058	1

\*Model number and serial number are required when ordering this part.

### L SERIES

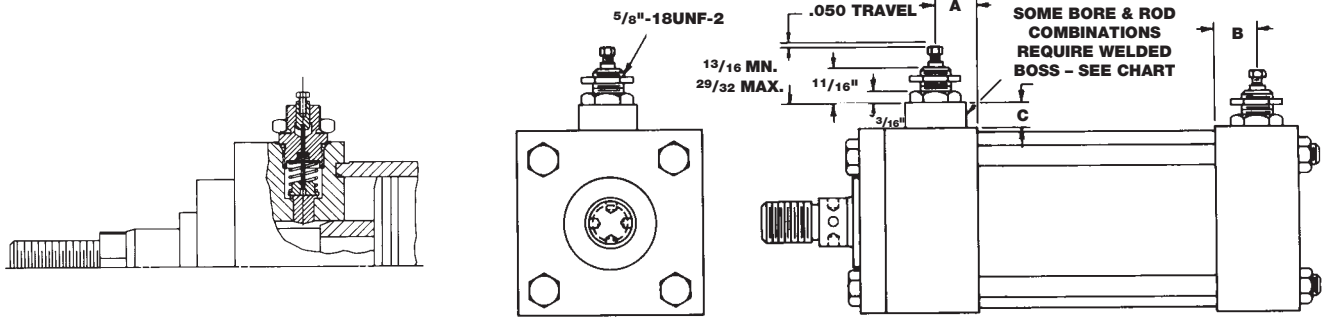

### LB AND LD SERIES

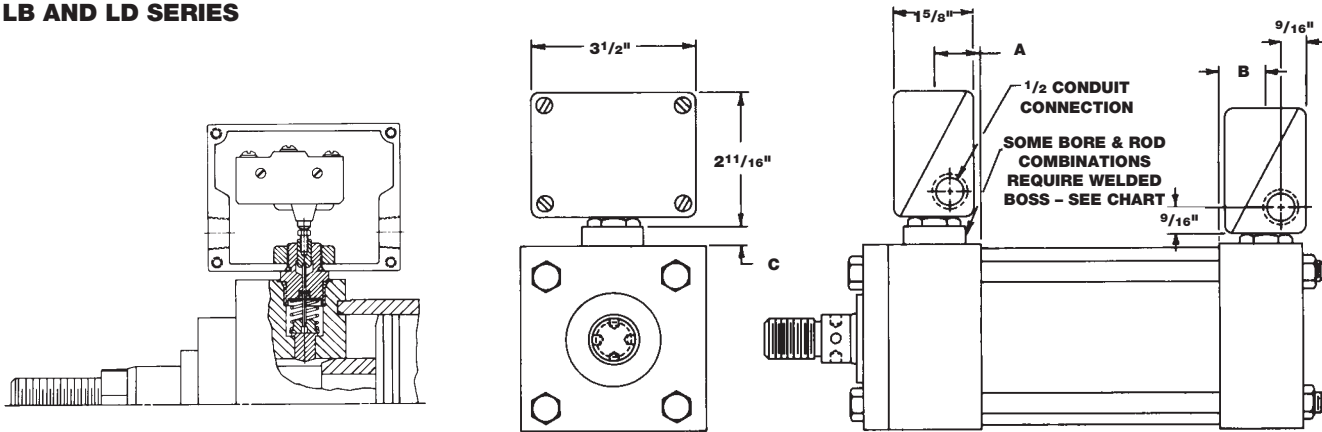

### LS SERIES

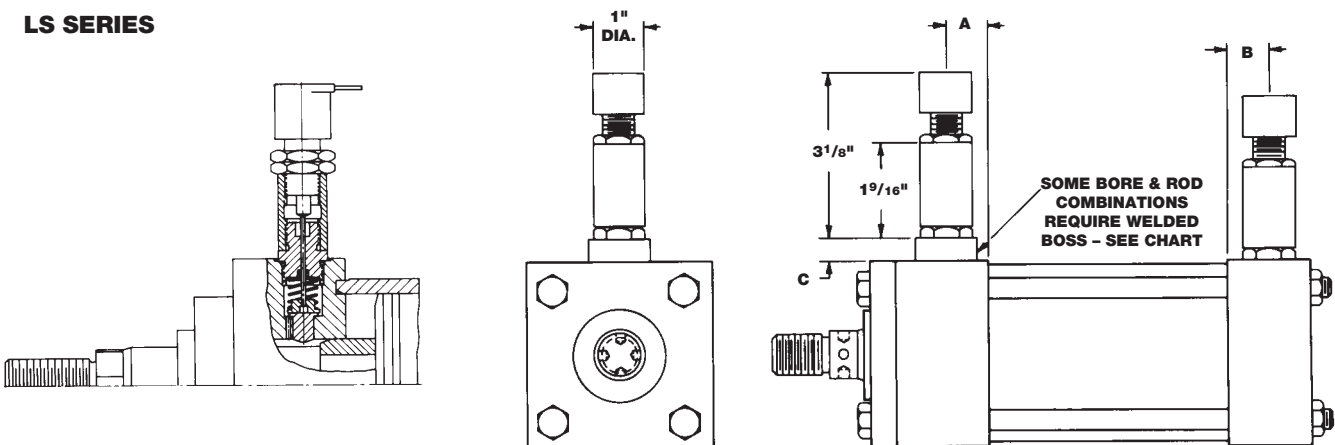

### LX SERIES

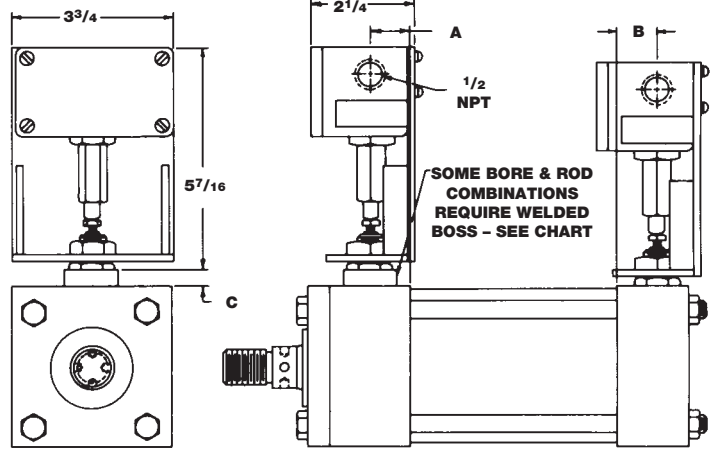

### LA SERIES

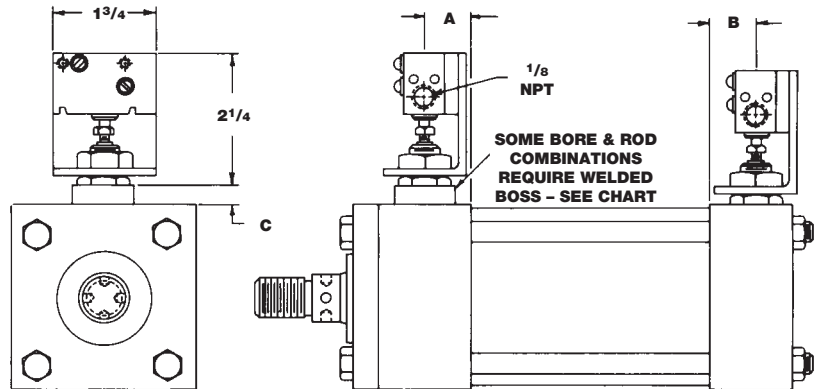

Switches are also available installed in the cap face as shown by **Illustration A**.

#### GENERAL NOTES:

When using limit switch operators for pneumatic service, assure that the system air is clean and dry. While operators are designed to be resistant to dirt and moisture, as with any fine machinery, lack of reasonable care can result in malfunction.

We will be pleased to quote you on either pneumatic or hydraulic cylinders with operators and custom mounting brackets for your selection of air valve or other signal device. Contact our distributor with your specific requirements.

#### ILLUSTRATION A

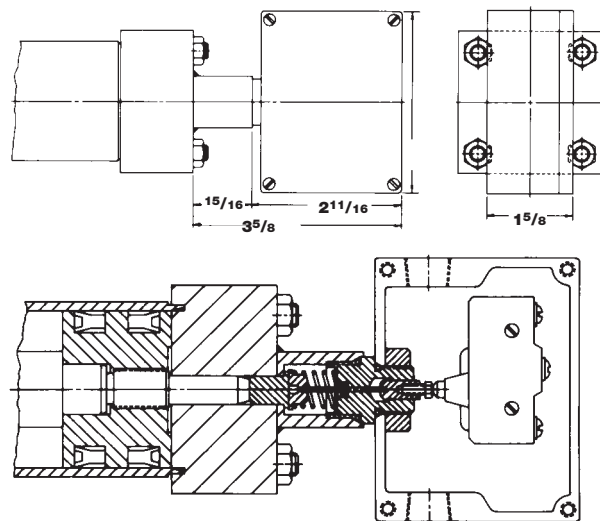

### A SERIES

BORE	ROD DIA.	HEAD		CAP	
		A	C	B	C
1 1/2	5/8	1/2	3/4	1/2†	3/4†
	1	1/2	3/4	1/2†	3/4†
2	5/8	1/2	1/2	7/16†	1/2†
	1*	1/2	3/4	7/16†	1/2†
	1 3/8	1/2	3/4	7/16†	1/2†
2 1/2	5/8	1/2	1/2	7/16†	1/2†
	1	1/2	1/2	7/16†	1/2†
	1 3/8	1/2	3/4	7/16†	1/2†
	1 3/4	1/2	3/4	7/16†	1/2†
3 1/4	1	5/8	1/2	1/2	—
	1 3/8	5/8	1/2	1/2	—
	1 3/4	5/8	1/2	1/2	—
	2	5/8	5/8	1/2	—
4	1	5/8	—	1/2	—
	1 3/8	5/8	—	1/2	—
	1 3/4	5/8	1/2	1/2	—
	2	5/8	1/2	1/2	—
	2 1/2	9/16	5/8	1/2	—
5	1	5/8	—	1/2	—
	1 3/8	5/8	—	1/2	—
	1 3/4	5/8	—	1/2	—
	2	5/8	—	1/2	—
	2 1/2	9/16	1/2	1/2	—
	3	1/2	1/2	1/2	—
6	3 1/2	1/2	5/8	1/2	—
	1 3/8	5/8	—	9/16	—
	1 3/4	9/16	—	9/16	—
	2	9/16	—	9/16	—
	2 1/2	9/16	—	9/16	—
	3	9/16	—	9/16	—
	3 1/2	9/16	1/2	9/16	—
7	4	1/2	1/2	9/16	—
	1 3/8	5/8	—	9/16	—
	1 3/4	9/16	—	9/16	—
	2	9/16	—	9/16	—
	2 1/2	9/16	—	9/16	—
	3	9/16	—	9/16	—
	3 1/2	9/16	—	9/16	—
	4	9/16	—	9/16	—
	4 1/2	9/16	1/2	9/16	—
8	5	9/16	1/2	9/16	—
	1 3/8	5/8	—	9/16	—
	1 3/4	9/16	—	9/16	—
	2	9/16	—	9/16	—
	2 1/2	9/16	—	9/16	—
	3	9/16	—	9/16	—
	3 1/2	9/16	—	9/16	—
	4	9/16	—	9/16	—
	4 1/2	9/16	—	9/16	—
	5	9/16	—	9/16	—
10	5 1/2	9/16	1/2	9/16	—
	1 3/4	7/8	—	7/8	—
	2	7/8	—	7/8	—
	2 1/2	7/8	—	7/8	—
	3	7/8	—	7/8	—
	3 1/2	7/8	—	7/8	—
	4	3/4	—	7/8	—
	4 1/2	13/16	—	7/8	—
5	13/16	—	7/8	—	
12	ALL	7/8	—	7/8	—
14	ALL	1	—	1	—

\* Not available with cushions.

†Because of possible interference, not recommended for RF, RFX, RX and BX mounts.

Always check dimensions for possible interference.

### MH SERIES

BORE	ROD DIA.	HEAD		CAP	
		A	C	B	C
1 1/2	5/8	5/8	3/4	9/16†	3/4†
	1	5/8	3/4	9/16†	3/4†
2	5/8	5/8	5/8	9/16†	1/2†
	1	5/8	3/4	9/16†	1/2†
	1 3/8	5/8	3/4	9/16†	1/2†
2 1/2	5/8	5/8	1/2	9/16†	1/2†
	1	5/8	1/2	9/16†	1/2†
	1 3/8	5/8	3/4	9/16†	1/2†
	1 3/4	5/8	3/4	9/16†	1/2†
3 1/4	1	5/8	1/2	5/8	—
	1 3/8	5/8	1/2	5/8	—
	1 3/4	3/4	1/2	5/8	—
	2	3/4	5/8	5/8	—
4	1	5/8	—	5/8	—
	1 3/8	5/8	—	5/8	—
	1 3/4	3/4	1/2	5/8	—
	2	3/4	1/2	5/8	—
	2 1/2	3/4	1/2	5/8	—
5	1	5/8	—	5/8	—
	1 3/8	5/8	—	5/8	—
	1 3/4	3/4	—	5/8	—
	2	3/4	—	5/8	—
	2 1/2	3/4	—	5/8	—
	3	21/32	1/2	5/8	—
6	3 1/2	21/32	1/2	5/8	—
	1 3/8	3/4	—	3/4	—
	1 3/4	3/4	—	3/4	—
	2	3/4	—	3/4	—
	2 1/2	3/4	—	3/4	—
	3	21/32	—	3/4	—
	3 1/2	21/32	—	3/4	—
7	4	21/32	1/2	3/4	—
	1 3/8	3/4	—	3/4	—
	1 3/4	3/4	—	3/4	—
	2	3/4	—	3/4	—
	2 1/2	3/4	—	3/4	—
	3	21/32	—	3/4	—
	3 1/2	21/32	—	3/4	—
	4	21/32	—	3/4	—
	4 1/2	21/32	—	3/4	—
8	5	21/32	1/2	3/4	—
	1 3/8	3/4	—	3/4	—
	1 3/4	3/4	—	3/4	—
	2	3/4	—	3/4	—
	2 1/2	3/4	—	3/4	—
	3	21/32	—	3/4	—
	3 1/2	21/32	—	3/4	—
	4	21/32	—	3/4	—
	4 1/2	21/32	—	3/4	—
	5	21/32	—	3/4	—
10	5 1/2	21/32	—	3/4	—

†Because of possible interference, not recommended for RF, RFX, RX and BX mounts.

Always check dimensions for possible interference.

### HH SERIES

BORE	ROD DIA.	HEAD		CAP	
		A	C	B	C
1 1/2	5/8	5/8	1/2	5/8	1/2
	1	5/8	1/2	5/8	1/2
2	1	5/8	1/2	3/4	1/2
	1 3/8	5/8	5/8	3/4	1/2
2 1/2	1	5/8	1/2	3/4	—
	1 3/8	5/8	1/2	3/4	—
	1 3/4	5/8	5/8	3/4	—
3 1/4	1 3/8	3/4	—	3/4	—
	1 3/4	3/4	1/2	3/4	—
	2	3/4	1/2	3/4	—
4	1 3/4	3/4	—	3/4	—
	2	3/4	—	3/4	—
	2 1/2	3/4	1/2	3/4	—
5	2	3/4	—	3/4	—
	2 1/2	3/4	—	3/4	—
	3	5/8	—	3/4	—
	3 1/2	3/4	—	3/4	—
6	2 1/2	1	—	1	—
	3	1	—	1	—
	3 1/2	1	—	1	—
	4	1	—	1	—
7	3	1	—	1	—
	3 1/2	1	—	1	—
	4	1	—	1	—
	4 1/2	1	—	1	—
8	5	1	—	1	—
	3 1/2	1	—	1	—
	4	1	—	1	—
	4 1/2	1	—	1	—
8	5	1	—	1	—
	5 1/2	1	—	1	—

Always check dimensions for possible interference.

### Cylinder Dimensions

For complete cylinder dimensions, please consult the appropriate cylinder brochure.

**A SERIES** – Pneumatic cylinders rated for pressures up to 250 psi. Steel, square head, ANSI interchangeable design.

**MH SERIES** – Hydraulic cylinders for medium service with pressures up to 2,000 psi, depending on bore size.

**HH SERIES** – Hydraulic cylinders rated for 3,000 psi operating pressure.

### SWITCH ADJUSTMENT

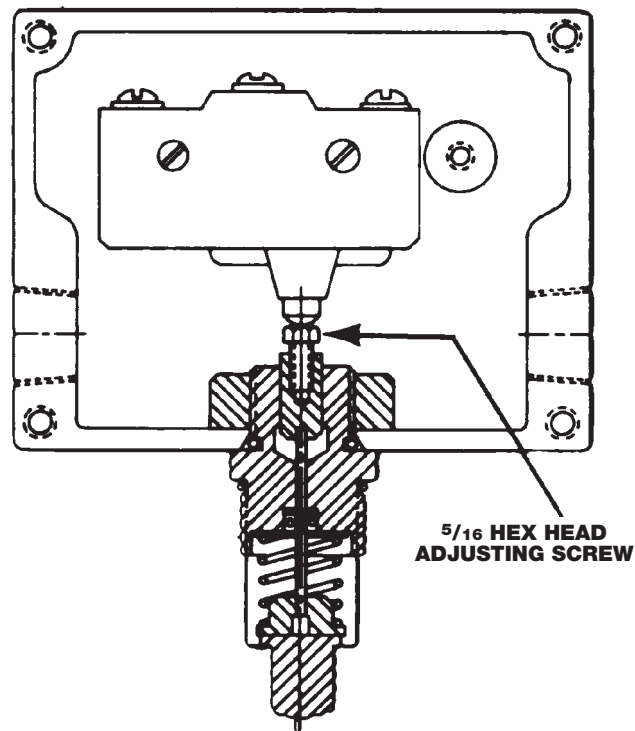

### Switch Adjustment

Switches are pre-set at the factory when assembled to the cylinder. They can, however, be field adjusted in the following manner:

#### Disconnect all electrical supply circuits.

Remove limit switch box cover.

If adjusting the switch on the head end of the cylinder (the end of the cylinder with the piston rod), retract the rod fully.

If adjusting the switch on the cap end of the cylinder, extend the piston rod fully.

Turn the hex head adjusting screw (see illustration) counter-clockwise until the limit switch clicks on. After the switch has clicked on, turn the hex head adjusting screw clockwise until the switch clicks off, then continue to turn clockwise an additional 1/4 turn.

Replace the limit switch box cover.

Reconnect the electrical supply circuits.

## Principles of Operation for Magnetic Proximity Switches

### Reed Switch Working Principle -

Our reed switch sensors contain hermetically sealed reed elements (mechanical contacts) which can be open or closed in their normal state depending on the version selected. When a magnetic field moves within proximity of the switch, magnetism is induced into the leads and forces the contact's state (open if normally closed or closed if normally open). Normally used with pneumatic cylinders that are built with internal magnetic pistons.

### Hall Effect / Magnetoresistive

**Working Principle -** Our "Hall effect" sensors actually use a solid state (no moving parts) magnetoresistive sensor instead of a typical Hall effect sensor. The magnetoresistive sensor responds to a North or South magnetic pole as shown to the right by providing a digital signal to the output control circuit. The magnetoresistive sensing technique enables our sensors to outperform typical Hall effect sensors by sensing much weaker magnetic fields. Also, there is no limit to the maximum strength of the magnetic field a magnetoresistive sensor will work with as opposed to a Hall effect sensor.

### Sinking (NPN) vs. Sourcing (PNP) -

Our DC Hall effect switches are available in sinking or sourcing versions. The basic difference between these two ways of solid state switching is as follows:

The SOURCING method connects or switches one side of the load to the positive side of the supply. The negative side is common or connected directly to the other side of the load as shown in **Figure 1**. PNP is the acronym used to describe the transistor that performs this type of switching in a solid state sensor.

The SINKING method connects or switches one side of the load to the negative side of the supply. The positive side is common or connected directly to the other side of the load as shown in **Figure 2**. NPN is the acronym used to describe the transistor that performs this type of switching in a solid state sensor.

## Which Type of Sensor Should I Use? Reed or Hall Effect?

The type of sensor that is best for a particular application depends on the operating parameters and cost related issues.

**Reed Switch Sensors -** If initial cost and versatility are most important, then reed switch sensors should be considered. For example, the type 04 reed switch will operate from 5 to 240 volts AC or DC. Generally, one switch can be stocked to cover a large majority of common applications. Please note, reed sensors do not work well with inrush surge currents and transients (common to inductive & capacitive loads; i.e. relays, coils & long wire runs). If inrush surge currents and transients must be accommodated, switch type 24 may be specified. These parameters should be given careful consideration when selecting a proximity device that will be best suited for an application.

**Hall Effect Sensors -** In general, if longevity is a major concern, Hall effect sensors should be used whenever they fit within the operating parameters specified for a given application. They should receive special attention when high cycle rates are required. If Hall effect sensors are used within their operating range, they will always outperform and outlast mechanical reed sensors. The initial added cost associated with a Hall effect sensor will be outweighed should the application require high cycle rates.

**Special Piston -** A special piston must be utilized in Magnetic Limit Switch cylinders. In addition to the magnetic strip and the bronze impregnated Teflon bearing strip, the piston is designed with a special endless ring seal of polyurethane filled with molybdenum disulphide. As shown in the illustration, the seal is expanded by an O-Ring. It seals in both directions. Low friction and no metal-to-metal contact afford smooth operation and extremely long life.

### PISTON CONSTRUCTION NO METAL-TO-METAL CONTACT

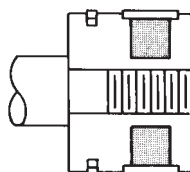

### REED SWITCH

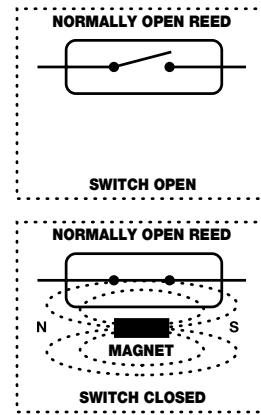

### HALL EFFECT/MAGNETORESISTIVE

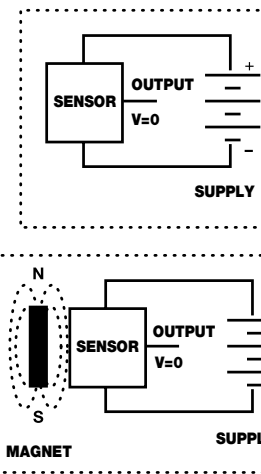

### SINKING (NPN) VS. SOURCING (PNP)

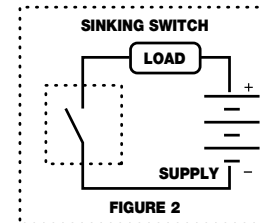
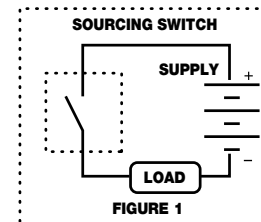





## Dimensional Data

### 728 SENSORS

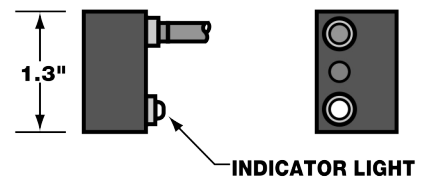
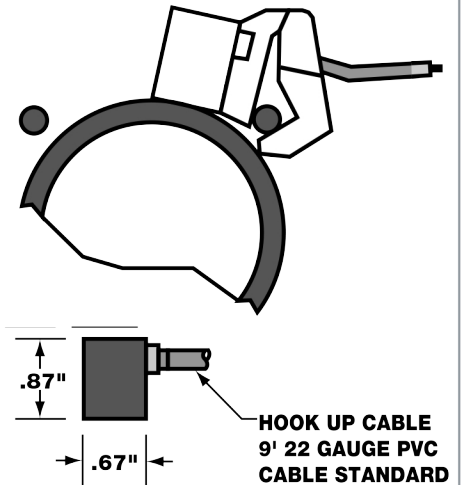

## 728 SERIES Magnetic Sensors for 2" TO 8" Bore Tie Rod Cylinders

728-000-0□□\*

Order by 9 Digit Part Number as a Separate Line Item

\* For 8" bore mounting change part number to 728-900-0□□

Type Code	Description	Function	Switching Voltage	Switching Current	Switching Power	Switching Speed	Voltage Drop
04	Reed Switch, MOV, LED, 2 Wire	Normally Open SPST	5-240 VDC/VAC 50/60 Hz	1 Amp Max. .005 Amp Min.	30 Watts Max.	0.6ms Operate 0.5ms Release	3 Volts
06	Reed Switch, LED, 3 Wire	Single Pole, Double Throw	5-120 VDC/VAC 50/60 Hz	1 Amp Max. .005 Amp Min.	20 Watts Max.	1.0ms Operate 0.02ms Release	3 Volts/load 1 0 Volts/load 2
09	Reed Switch, MOV, LED, 2 Wire	Normally Closed SPST	5-120 VDC/VAC 50/60 Hz	1 Amp Max. .005 Amp Min.	20 Watts Max.	1.0ms Operate 0.02ms Release	3 Volts
24	Reed Switch, MOV, LED, 3 Wire	Normally Open TRIAC Output	24-240 VAC 50/60 Hz	4 Amp Max. 50 Amp Inrush .005 Amp Min.	100 Watts Max.	0.6ms Operate 0.05ms Release	1 Volt
31	Hall Effect for Reed Magnets, LED, Sourcing, 3 Wire	Normally Open PNP Output	6-24 VDC	1 Amp Max.	24 Watts Max.	1.5us Operate 0.5us Release	0.5 Volts
32	Hall Effect for Reed Magnets, LED, Sinking, 3 Wire	Normally Open NPN Output	6-24 VDC	1 Amp Max.	24 Watts Max.	1.5us Operate 0.5us Release	0.5 Volts

Important Note: The 728 & 828 switches are not interchangeable with old series 10 or 100 switches or cylinders.

### 828 SENSORS

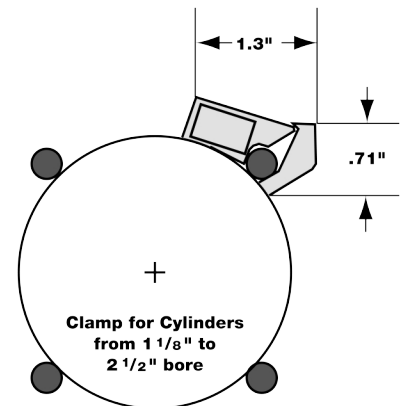

## 828 SERIES Magnetic Sensors for 1 1/8" to 2 1/2" Bore Tie Rod Cylinders

828-200-0□□

Order by 9 Digit Part Number as a Separate Line Item

Type Code	Description	Function	Switching Voltage	Switching Current	Switching Power	Switching Speed	Voltage Drop
04	Reed Switch, MOV, LED	SPST Normally Open	5-120 VDC/VAC 50/60 Hz	0.5 Amp Max. 0.005 Amp Min.	10 Watts Max.	0.5ms Operate 0.1ms Release	3.5 Volts
31	Hall Effect, LED Sourcing	Normally Open PNP Output	6-24 VDC	0.5 Amp Max.	12 Watts Max.	1.5us Operate 0.5us Release	0.5 Volts
32	Hall Effect, LED Sinking	Normally Open NPN Output	6-24 VDC	0.5 Amp Max.	12 Watts Max.	1.5us Operate 0.5us Release	0.5 Volts

Important Note: The 728 & 828 switches are not interchangeable with old series 10 or 100 switches or cylinders.

### 9' PVC CABLE SWITCH TYPE 0

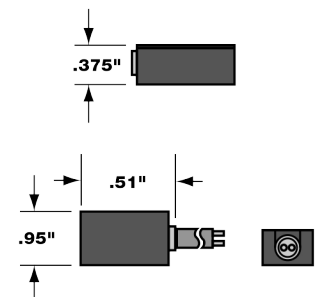

9 ft. 24 Gauge PVC Cable Standard

See Next Page for Series 728 & 828 Features and Technical Data



## Series 728 and Series 828 Specifications

### FEATURES

- Wide voltage range (5-240 Volts AC or DC)
- Compact design
- Extremely consistent repeatability
- High intensity LED on all models offered
- Compatible with most corrosive and washdown applications
- Both Hall effect and reed switches work with same piston magnet

### TECHNICAL DATA

- Temperature Range: from -30°C to +80°C
- Shock - Operational up to 30G (11 msec.) reeds only. Not applicable for Halls
- Vibration - Operational up to 20G (10-55Hz) reeds only. Not applicable for Halls
- Most versions designed to meet NEMA 6 specifications
- CSA versions available on special order
- Hall effect compatible with intrinsically safe barriers

## Proximity Sensor Type Descriptions

### Reed Switch Sensors

**Type 04 & 09** - The type 04 is single pole single throw (SPST) normally open and type 09 is single pole single throw normally closed. Both act as an in line switch which is actuated in a magnetic field. These sensors also include an LED indicator and surge suppression. The LED indicator operates when the switch is made with a minimum 5mA current flowing through the switch, and a typical 3 volt drop. Surge suppression helps to extend the life of the sensor when it is used to switch higher current loads and/or inductive loads.

**Type 06** - This sensor is a reed-type sensor which uses a single pole double throw (SPDT) element. This enables the switching of two separate loads. One side of the switch is normally closed and the other is normally open. This sensor also includes an LED indicator which is connected to the normally open side of the switch. The LED indicator operates when the normal open side is closed with a minimum 5mA current flowing through the switch and a typical 3 volt drop.

**Type 24** - This sensor is designed specifically to switch high power AC loads (including inductive loads) and loads with high transient or inrush currents, although they are not limited to these applications. This switch uses a reed element to sense a magnetic field and a triac to drive the output. This sensor includes standard surge suppression. This configuration provides for excellent longevity even under the most demanding conditions. The type 24 is normally open.

### Hall Effect Sensors

**Type 31 & 32** - These sensors use magnetoresistive elements (similar to Hall effect) with no magnetic polarity and much greater sensitivity with no maximum gauss level. They are 100% solid state (no moving parts = LONG LIFE). They are designed to operate with voltages from 6 to 24V DC and are provided in two normally open configurations: NPN (Sinking) output and PNP (Sourcing) output. Both include an indicator light which illuminates when the switch is actuated. No minimum load current and low voltage drop make them ideal for use with programmable controllers.

## 828 and 728 SERIES Schematic Representations

### TYPE 04 & 09

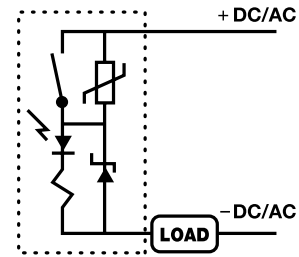

### TYPE 06

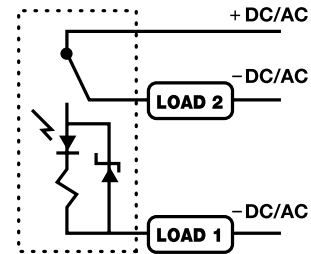

### TYPE 24

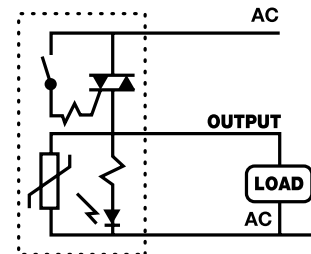

### TYPE 31

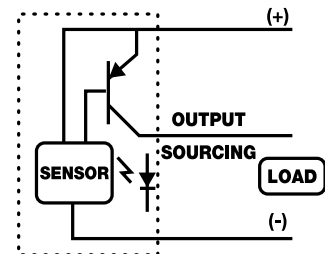

### TYPE 32

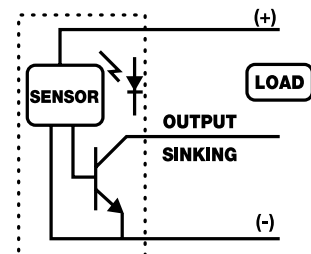

# S.A.F.E. Coupling

SELF-ALIGNING FLANGE END

## Design Data

With the CylindersNow S.A.F.E. (Self-Aligning Flange End) Coupling, close radial alignment between cylinder rod end and machine member is easily and quickly achieved. Thus, cylinder installation is faster, cylinder life longer.

Consider how a threaded rod end is usually joined to a machine member. First, the hole for the rod end must be located, then drilled or bored, and tapped or chased. These are critical operations and to avoid misalignment, they must be done with extreme care. (Boring and chasing equipment are not always available.)

With the CylindersNow S.A.F.E. Coupling, however, mounting goes fast. Using the bolt circle information on this page, the mounting holes are scribed, drilled and tapped. Close radial alignment is achieved every time!

Because correct alignment means less wear of component parts, CylindersNow S.A.F.E. Coupling allows for radial misalignment without causing abnormal rod bearing wear, short seal life, or possible damage to the I.D. of the cylinder tube. It is not designed, however, to compensate for angular misalignment. For this problem, ask your distributor about the CylindersNow R.A.C. (Rod Aligning Coupler) mounting accessory. (See also Page AC-15.)

The S.A.F.E. Coupling also assures a stronger connection between rod end and machine member than a threaded rod end. The flat rod end takes the full load on the push stroke, and the machined shoulder of the rod and the S.A.F.E. Coupling take the maximum loading force that the cylinder is capable of producing on the pull stroke.

The flange is made from solid steel. High tensile, socket head cap screws, designed to take full loading with a safety factor, are provided. S.A.F.E. Coupling is for use with CylindersNow Style 6 rod ends.

## Dimensions

PART NO.	ROD DIA. MM	A*	B	E	F*	H	M	N	P	R	S	V	WELD PLATE NO.	D	G	W	BOLT TORQ. FT. LB.
S.A.F.E. 0050	1/2	5/16	1	7/16	11/32	13/8	10-24	4	1	45	90	3/8	WP-0050	1/2	2	1/4	5
S.A.F.E. 0062	5/8	3/8	1 1/8	9/16	13/32	1 1/2	10-24	4	1 1/8	45	90	3/8	WP-0062	1/2	2	1/4	5
S.A.F.E. 0075	3/4	7/16	1 1/4	5/8	1/2	1 5/8	10-24	4	1 1/4	45	90	3/8	WP-0075	1/2	2 1/4	1/4	5
S.A.F.E. 0100	1	1 1/16	1 1/2	7/8	3/4	2	1/4-20	6	1 1/2	30	60	3/8	WP-0100	1/2	2 1/2	1/4	13
S.A.F.E. 0112	1 1/8	3/4	1 1/2	7/8	13/16	2 1/8	1/4-20	6	1 5/8	30	60	3/8	WP-0112	1/2	2 1/2	1/4	13
S.A.F.E. 0125	1 1/4	13/16	1 1/2	7/8	7/8	2 1/4	1/4-20	6	1 3/4	30	60	3/8	WP-0125	1/2	3	1/4	13
S.A.F.E. 0137	1 3/8	7/8	1 3/4	1	15/16	2 1/2	5/16-18	6	2	30	60	1/2	WP-0137	5/8	3	1/4	27
S.A.F.E. 0175	1 3/4	1 1/8	2	1 1/4	1 3/4	3	5/16-18	8	2 3/8	22 1/2	45	1/2	WP-0175	5/8	4	1/4	27
S.A.F.E. 0200	2	1 3/8	2 5/8	1 5/8	1 7/16	3 1/2	3/8-16	12	2 1 1/16	15	30	5/8	WP-0200	3/4	4	3/8	48
S.A.F.E. 0250	2 1/2	1 3/4	3 1/4	1 7/8	1 7/8	4	3/8-16	12	3 3/16	15	30	5/8	WP-0250	3/4	4 1/2	3/8	48
S.A.F.E. 0300	3	2 1/4	3 3/4	2 3/8	2 3/8	5	1/2-13	12	4	15	30	7/8	WP-0300	1	5 1/2	3/8	118
S.A.F.E. 0350	3 1/2	2 1/2	4 3/8	2 5/8	2 5/8	5 7/8	5/8-11	12	4 1 1/16	15	30	7/8	WP-0350	1	7	3/8	235
S.A.F.E. 0400	4	3	4 1/2	2 5/8	3 1/8	6 3/8	5/8-11	12	5 3/16	15	30	7/8	WP-0400	1	7	3/8	235
S.A.F.E. 0450	4 1/2	3 1/2	5 1/4	3 1/8	3 5/8	6 7/8	5/8-11	12	5 1 1/16	15	30	7/8	WP-0450	1	8	3/8	235
S.A.F.E. 0500	5	3 7/8	5 3/8	3 1/8	4	7 3/8	5/8-11	12	6 3/16	15	30	7/8	WP-0500	1	8	3/8	235
S.A.F.E. 0550	5 1/2	4 3/8	6 1/4	3 7/8	4 1/2	8 1/4	3/4-10	12	6 7/8	15	30	1 1/8	WP-0550	1 1/4	9	3/8	415

\*F dimension minus A dimension is radial clearance.



Also available as a convenient accessory (optional at extra cost) is a Weld Plate to match each S.A.F.E. Coupling. Shown on the adjacent drawing, the Weld Plate provides the perfect answer to the customer who would prefer to weld a pre-drilled and tapped, properly sized plate to the machine member, rather than laying out, drilling and tapping each hole in the member itself. The Weld Plate is equipped with an accurately drilled locator pin hole to facilitate fast, close tolerance positioning. Low carbon steel is used for ease in welding.

**Faster close radial alignment important for long cylinder life**

**Less critical rod end to machine attachment**

**Use with any CylindersNow cylinder with 1/2" or larger rod diameter**

**Use with no-extra-cost CylindersNow style 6 rod end**

**Faster cylinder installation and removal**

**Better force distribution on push and pull strokes**

**High tensile, socket head cap screws provided**

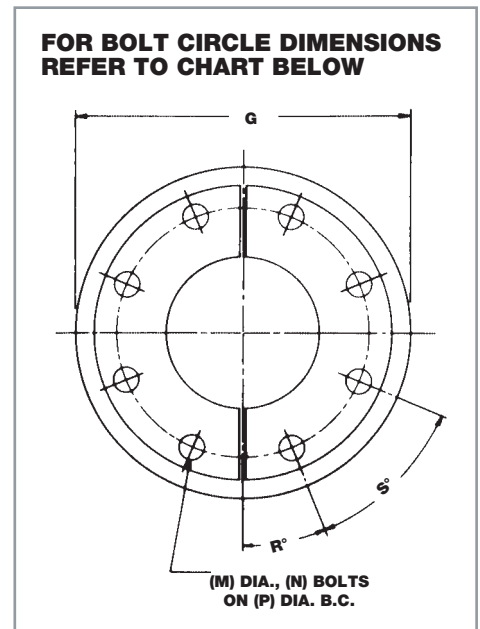
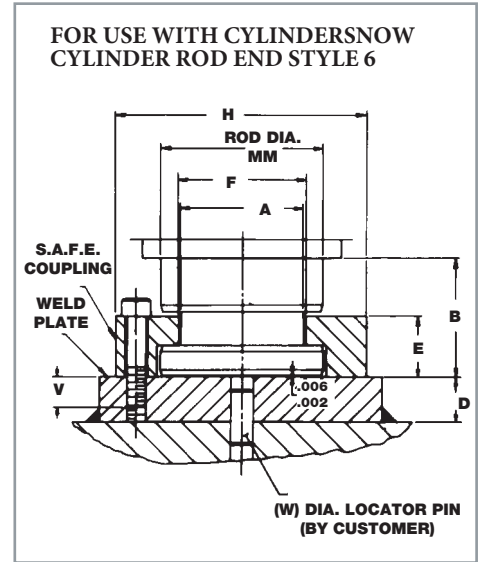

## Reduces Misalignment Problems!

Much effort has been made by many to relieve, or eliminate the side loading of cylinders created as a result of misalignment. It is, of course, almost impossible to get perfect alignment and since the alignment of the cylinder has a direct bearing on its life, the efforts have been well worth while.

A spherical bushing used by The CylindersNow and most everyone else in the cylinder industry, for various applications, is excellent and serves a very useful purpose. It does, however, have some very definite limitations. First and foremost among these is its inability, with the limited space available, to take the loads that the cylinder is capable of producing. The second deficiency of the spherical bushing or bearing is that it is limited to a maximum misalignment of five degrees and can act as a complete hinge in one direction only.

With the CylindersNow UNI-LIGN most, if not all, of these limitations have been eliminated. For instance, fifteen degrees each side of center is a reasonable angular misalignment at the pins, at the cylinder clevis and the rod clevis, increasing by three times the capabilities of the spherical bushing, plus providing maximum load carrying capabilities. It is recommended that not more than a thirty degree maximum angle be used on the pins in the out-board end of the UNI-LIGN units. However, when lighter than maximum loads are encountered, as much as 90 degrees could be used with complete safety.



All components, pins, UNI-LIGN and mounting brackets are designed to take maximum loading of the cylinder where pin sizes match that of the clevis mount cylinder. All matching accessories and clevis mounts for cataloged cylinders are catalog standard. Time saved in installation may very well pay for the entire cost of the application.

- No special fitting
- Gives freer range of mounting positions
- Simplifies machine design requirements
- Reduces cylinder binding and slide-loading
- Allows universal swivel
- Less critical machining
- Reduces bearing and tube wear
- Eliminates piston blow-by from misalignment
- Works with standard mounting accessories

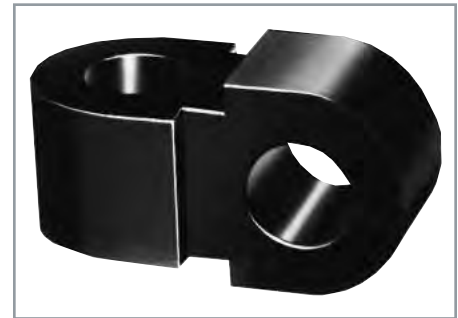

## MOUNTING INFORMATION

Maximum recommended angular deviation from center line:

INBOARD PIN-15°  
OUTBOARD PIN-30°

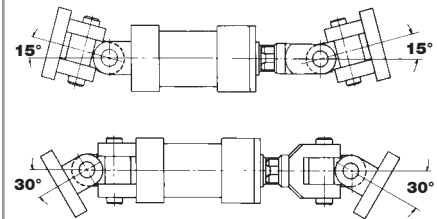

A-A – PRIMARY PIVOT PLANE  
(FOR AXIAL LOADING OF CYLINDER)

B-B – SECONDARY PIVOT PLANE  
(FOR MISALIGNMENT OF CYLINDER)

## CORRECT

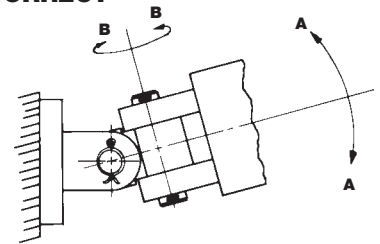

## INCORRECT

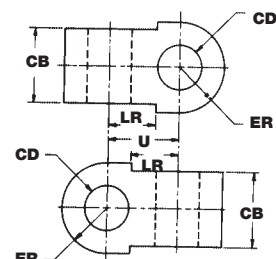
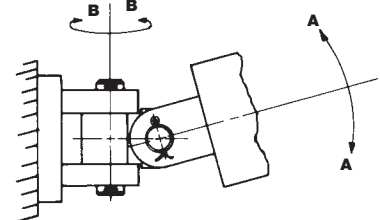

## Dimensions

FOR USE WITH CYLINDERSNOW CLEVIS MOUNT		UNI-LIGN PART NO.	CLEVIS MOUNTING BRACKET PART NO.	ROD CLEVIS PART NO.	DIMENSIONS				
A & MH SERIES CYLINDERS BORE SIZE	HH SERIES CYLINDERS BORE SIZE				CB	CD PIN	ER RAD.	LR	U
1 1/8	1 1/8	UL-10	MBC-A30510	CLS-A2043	5/8	3/8	3/8	7/16	5/8
1 1/2, 2 AND 2 1/2	1 1/2	UL-14	MBC-A40614	CLS-A1043	3/4	1/2	1/2	35/64	7/8
3 1/2, 4 AND 5	2, 2 1/2	UL-19	MBC-A61020	CLS-A10750	1 1/4	3/4	3/4	51/64	1 3/16
6, 7 AND 8	3 1/4	UL-27	MBC-A81224	CLS-A11000	1 1/2	1	1	1 3/64	1 11/16
10	4	UL-38	MBC-A111632	CLS-A11250	2	1 3/8	1 3/8	1 7/16	2 3/8
12	5	UL-49	MBC-A142040	CLS-A11500	2 1/2	1 3/4	1 3/4	1 13/16	3 1/16
14	6	UL-58	MBC-A142040 MBC-A162040	CLS-A11870	2 1/2	2	2	2 1/16	3 5/8

†For A SERIES

# Clevis & Pivot Mounting Brackets

## Clevis and Pivot Mounting Brackets

PART NUMBER CLEVIS	PART NUMBER PIVOT	SERIES*					CB	CD	CL	CW	DD (BOLT SIZE)	E	F	FL	LR	MR	R	MATCHING ROD EYE REF/REM	WT. IN LBS.
		A	C20	MA	HH	MH													
—	MBP-101		•				3/4	1/2	—	—	5/16	2 1/2	7/16	1 1/2	—	1/2	1 3/4	-80406 -100408	1
—	MBP-102		•				1 1/4	3/4	—	—	1/2	3 1/4	1/2	1 5/8	—	3/4	2 1/4	-120610	2 1/8
—	MBP-104		•				1 1/2	1	—	—	5/8	4 1/2	7/8	2 1/4	—	1	3	-160812	4 1/2
MBC-A30510	MBP-305	•			•	•	5/8	3/8	1 1/4	5/16	1/4-28**	1 5/8	5/16	1 5/16	9/16	3/8	1.19	-50305 -70305	3/8
MBC-A40614	MBP-406	•			•	•	3/4	1/2	1 3/4	1/2	3/8	2 1/2	3/8	1 1/8	1/2	1/2	1.63	-70406	1
MBC-A61020	MBP-610	•			•	•	1 1/4	3/4	2 1/2	5/8	1/2	3 1/2	5/8	1 7/8	1 5/16	3/4	2.55	-120610	3/8
MBC-A81224	MBP-812	•			•	•	1 1/2	1	3	3/4	5/8	4 1/2	3/4	2 1/4	1 3/16	1	3.25	-160812	1/2
MBC-A111632	MBP-1116	•			•	•	2	1 3/8	4	1	5/8	5	7/8	3	1 3/4	1 3/8	3.82	-201116	1 1/2
MBC-A142040	MBP-1420	•			•	•	2 1/2	1 3/4	5	1 1/4	7/8	6 1/2	7/8	3 1/8	1 7/8	1 3/4	4.95	-241420	2 1/2
MBC-A162040	MBP-1620	•			•	•	2 1/2	2	5	1 1/4	1	7 1/2	1	3 1/2	2 1/16	2	5.73	-301620	30
MBC-A202448	MBP-2024				•	•	3	2 1/2	6	1 1/2	1 1/8	8 1/2	1	4	2 1/2	2 1/2	6.58	-362024	46
MBC-A242448	MBP-2424				•	•	3	3	6	1 1/2	1 1/4	9 1/2	1	4 1/4	2 3/4	2 3/4	7.50	-402424	58
MBC-A242856	—				•	•	3 1/2	3	7	1 3/4	1 1/4	10	1 1/4	5	3 1/4	3	8.00	-482428	61
MBC-A283264	MBP-2832				•	•	4	3 1/2	8	2	1 3/4	12 5/8	1 11/16	5 11/16	3 1/2	3 1/2	9.62	-522832 -562832	108
MBC-A323672	MBP-3236				•	•	4 1/2	4	9	2 1/4	2	14 7/8	1 15/16	6 7/16	4	4	11.45	-643236	175
MBC-A404896	MBP-4048				•		6	5	12	3	2 1/4	17 1/4	2 7/16	8 15/16	5 1/4	5	13.34	-844048	—
832-040614	821-0406		•				3/4	1/2	—	1/2	+3/8-24	2 1/2	3/8	1 1/8	9/16	9/16	1 5/8	-70406	—
832-061020	821-0610		•				1 1/4	3/4	—	5/8	+1/2-20	3 1/2	5/8	1 7/8	1	1 3/16	2 9/16	-120610	—
832-081224	821-0812		•				1 1/2	1	—	3/4	+5/8-18	4 1/2	3/4	2 1/4	1 1/8	1	3 1/4	-160812	—
MBC-A111632	821-1116		•				2	1 3/8	—	1	5/8	5	7/8	3	1 3/4	1 3/8	3 13/16	-201116	—

\*NOTES:

A, MA, HH and MH SERIES: Pins and Retainers supplied with Clevis Mounting Brackets.

C20 SERIES: Pins not included. Pins are furnished with matching cylinders.

\*\*Indicates tapped holes

+Tapped holes on 832 Series; Clearance Holes for indicated bolts on 821 Series

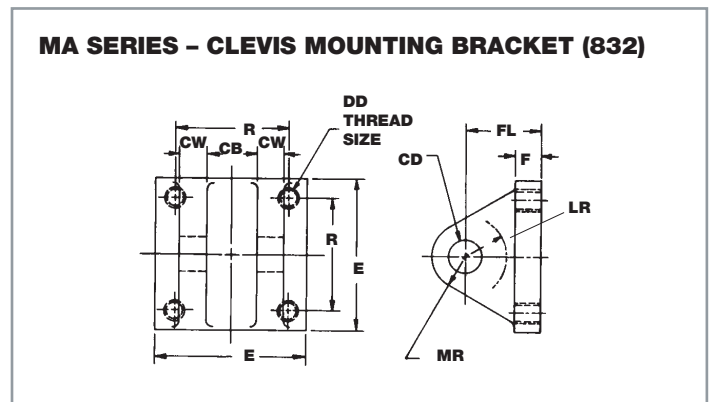
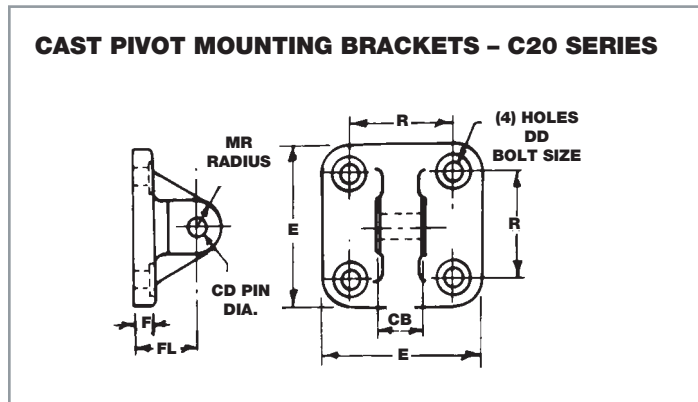
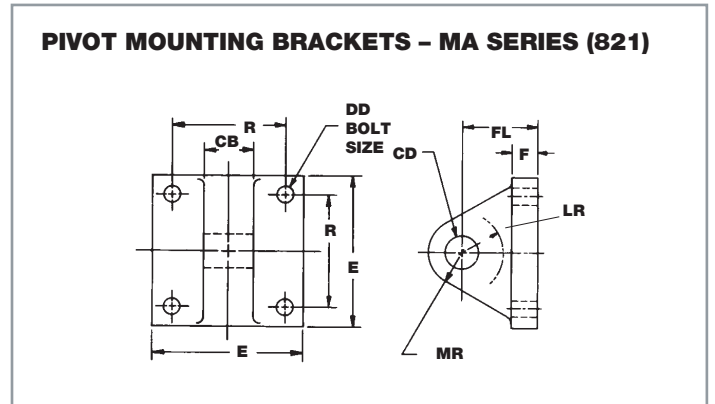
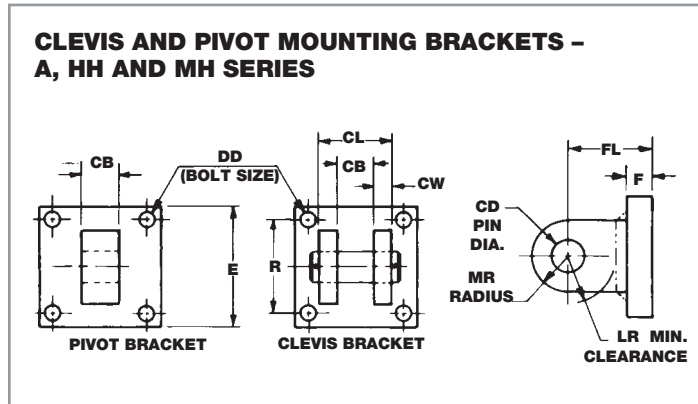

## A SERIES - CAST CLEVIS AND PINS

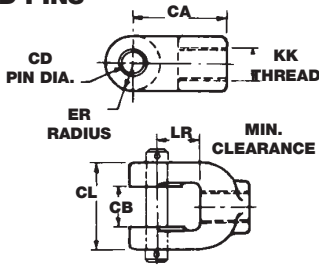

## Cast Clevises and Pins

PART NUMBER	SERIES		KK THREAD	CA	CB	CD PIN DIA.	CE	CL	A THD	ER RAD.	LR	WEIGHT
	A	C20										
CLC-A175	•	•	3/4-16	2	3/4	5/8	2	13/4	7/8	5/8	11/8	1 1/2 LBS.
CLC-A1104	•	•	1-14	2 1/2	1 1/4	3/4	2 1/2	2 1/2	1 1/4	3/4	1 1/4	1 5/8 LBS.
CLC-A1125	•	•	1 1/4-12	3 1/2	1 1/2	1	3 1/2	3 3/4	2	1 1/8	1 1/2	5 3/4 LBS.
CLC-A1137	•	•	1 3/8-12	—	1 1/2	1	3 1/2	3 3/4	2	1 1/8	2 1/2	5 1/2 LBS.
CLC-A1150	•	•	1 1/2-12	5	2 1/2	1 3/8	—	6	—	1 1/2	2 1/2	—
CLC-A1187	•	•	1 7/8-12	5	2 1/2	1 3/8	—	6	—	1 1/2	2 1/2	—

## A, C20, MA, AND MH SERIES - FORGED STEEL CLEAVES AND PINS

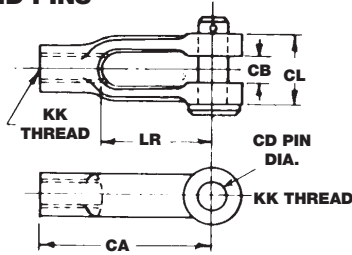

## Forged Steel Clevises and Pins

PART NUMBER	SERIES				KK THREAD	CA	CB	CD PIN DIA.	CL	LR	WEIGHT
	A	C20	MA	MH							
CLF-A343	•	•	•	•	7/16-20	2 7/8	1/2	7/16	1	1 7/8	5 1/16 LB.
CLF-A350	•	•	•	•	1/2-20	3	9/16	1/2	1 1/8	1 7/8	7 1/16 LB.
CLF-A362	•	•	•	•	5/8-18	4 15/16	11/16	5/8	1 3/8	3 11/16	1 LB.
CLF-A375	•	•	•	•	3/4-16	6 1/16	13/16	3/4	1 5/8	4 9/16	1 3/4 LBS.
CLF-A387	•	•	•	•	7/8-14	7 1/8	15/16	7/8	1 7/8	5 1/4	2 5/8 LBS.
CLF-A3100	•	•	•	•	1-14	8	1 1/16	1	2 1/8	6	3 5/8 LBS.
CLP-A331	•	•	•	•	5/16-24	2 1/4	1 1/32	5/16	3/4	1 7/16	2 OZ.

\*\*Note: CLP-A331 is a Plastic Clevis  
CLS-A331 is a Steel Clevis

## JAM NUTS

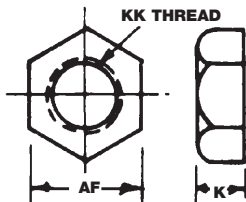

## Jam Nuts

PART NUMBER	STEEL PLATED								KK THD.	AF	K	WEIGHT
	A	AA	C-20	CLA	MA	CLH	HH	MH				
3JN-25	•	•	•	•	•	•	•	•	1/4-28	7/16	7/32	3/16 OZ.
3JN-31	•	•	•	•	•	•	•	•	5/16-24	1/2	7/32	1/4 OZ.
3JN-43	•	•	•	•	•	•	•	•	7/16-20	11/16	1/4	3/8 LB.
3JN-50	•	•	•	•	•	•	•	•	1/2-20	3/4	5/16	1/2 LB.
3JN-62	•	•	•	•	•	•	•	•	5/8-18	15/16	3/8	3/4 LB.
3JN-75	•	•	•	•	•	•	•	•	3/4-16	1 1/16	3/8	1 LB.
3JN-87	•	•	•	•	•	•	•	•	7/8-14	1 1/4	7/16	2 LBS.
3JN-100	•	•	•	•	•	•	•	•	1-14	1 7/16	1/2	3 LBS.
3JN-125	•	•	•	•	•	•	•	•	1 1/4-12	1 13/16	5/8	5 LBS.
3JN-137	•	•	•	•	•	•	•	•	1 3/8-12	2	3/4	5 1/16 LBS.
3JN-150	•	•	•	•	•	•	•	•	1 1/2-12	2 3/16	13/16	9 LBS.
3JN-175	•	•	•	•	•	•	•	•	1 3/4-12	2 5/8	31/32	1 LB.
3JN-187	•	•	•	•	•	•	•	•	1 7/8-12	2 3/4	1 1/32	1 1/8 LBS.
3JN-200	•	•	•	•	•	•	•	•	2-12	3	1 3/32	1 3/8 LBS.
3JN-225	•	•	•	•	•	•	•	•	2 1/4-12	3 3/8	1 13/64	2 LBS.
3JN-250	•	•	•	•	•	•	•	•	2 1/2-12	3 3/4	1 29/64	2 7/8 LBS.
3JN-275	•	•	•	•	•	•	•	•	2 3/4-12	4 1/8	1 37/64	4 1/8 LBS.
3JN-300	•	•	•	•	•	•	•	•	3-12	4 1/2	1 45/64	4 5/8 LBS.
3JN-325	•	•	•	•	•	•	•	•	3 1/4-12	5	1 13/16	6 1/4 LBS.
3JN-350	•	•	•	•	•	•	•	•	3 1/2-12	5 3/8	1 15/16	8 3/16 LBS.
3JN-375	•	•	•	•	•	•	•	•	3 3/4-12	5 3/4	2 1/16	9 5/8 LBS.
3JN-400	•	•	•	•	•	•	•	•	4-12	6 1/8	2 3/16	11 LBS.



### Rod Clevis and Pins

PART NUMBER	STEEL PLATED					KK THD.	A THD. DEPTH.	CA	CB	CD PIN DIA.	CE	CL	CW	E	ER RAD.	LR	S	WEIGHT
	A	C20	MA	HH	MH													
CLS-A031	•					5/16-24	3/8	—	1/4	5/16	13/16	5/8	—	—	5/16	3/8	—	1 OZ.
CLS-A1043	•		•	•	•	7/16-20	3/4	—	3/4	1/2	11/2	11/2	—	—	1/2	3/4	—	1/2 LB.
CLS-A1050	•	•	•	•	•	1/2-20	3/4	—	3/4	1/2	11/2	11/2	—	—	1/2	3/4	—	1/2 LB.
CLS-A1062		•				5/8-18	3/4	—	3/4	1/2	11/2	11/2	—	—	1/2	3/4	—	1/2 LB.
CLS-A10750	•	•		•	•	3/4-16	11/8	—	11/4	3/4	21/8	21/2	—	—	3/4	1	—	17/8 LBS.
CLS-A10870	•			•	•	7/8-14	11/8	—	11/4	3/4	21/8	21/2	—	—	3/4	1	—	2 LBS.
CLS-A11000	•	•		•	•	1-14	15/8	—	11/2	1	215/16	3	—	—	1	15/16	—	33/8 LBS.
CLS-A11250	•	•		•	•	11/4-12	2	—	2	13/8	33/4	4	—	—	13/8	13/4	—	8 LBS.
CLS-A11500	•			•	•	11/2-12	21/4	—	21/2	13/4	41/2	5	—	—	13/4	21/4	—	15 LBS.
CLS-A11750	•			•	•	13/4-12	3	—	21/2	2	51/2	5	—	—	2	21/2	—	25 LBS.
CLS-A11870	•			•	•	17/8-12	3	—	21/2	2	51/2	5	—	—	2	21/2	—	24 LBS.
CLS-A12250	•			•	•	21/4-12	31/2	—	3	21/2	61/2	6	—	—	21/2	3	—	35 LBS.
CLS-A12500	•			•	•	21/2-12	31/2	—	3	3	63/4	6	—	—	23/4	31/4	—	44 LBS.
CLS-A12750	•			•	•	23/4-12	31/2	—	3	3	63/4	6	—	—	23/4	31/4	—	43 LBS.
CLS-A13000	•			•	•	3-12	41/2	—	3	3	81/2	8	—	—	31/2	4	—	125 LBS.
CLS-A13250	•			•	•	31/4-12	41/2	—	4	31/2	81/2	8	—	—	31/2	4	—	130 LBS.
CLS-A13500	•			•	•	31/2-12	5	—	4	31/2	9	8	—	—	31/2	4	—	131 LBS.
CLS-A14000	•			•	•	4-12	51/2	—	41/2	4	10	9	—	—	4	41/2	—	180 LBS.
807-10750			•			3/4-16	11/8	—	11/4	3/4	23/8	21/2	—	—	3/4	11/4	—	—
807-11000			•			1-14	15/8	—	11/2	1	31/8	3	—	—	1	11/2	—	—
807-11250			•			11/4-12	2	—	2	13/8	41/8	4	—	—	13/8	21/8	—	—

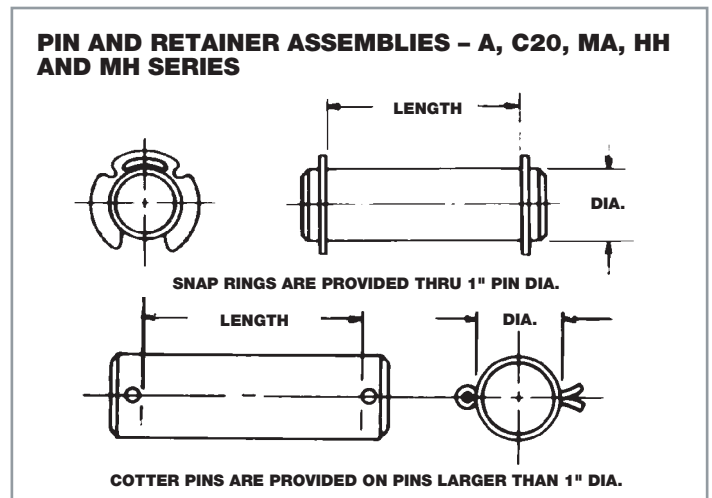
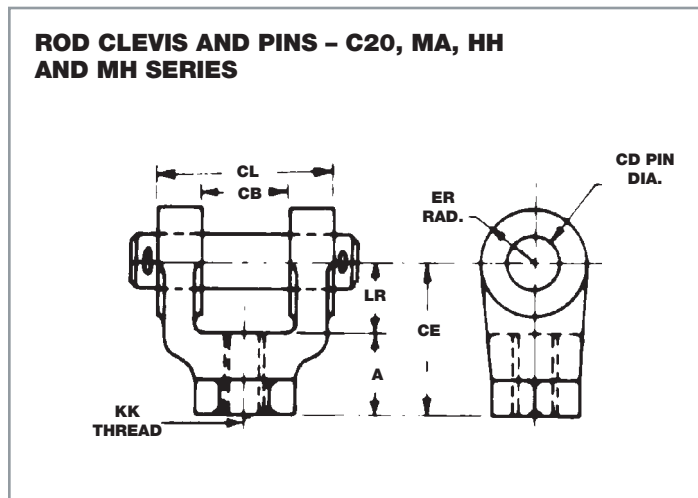

### Pin and Retainer Assemblies

PART NUMBER	SERIES					NOMINAL PIN SIZE		TO MATCH MOUNTING BRACKET	TO MATCH ROD EYES REM/REF	WEIGHT IN POUNDS
	A	C20	MA	HH	MH	DIAMETER	LENGTH			
PC-A310	•			•	•	3/8	11/4	MBC-A30510	-50305 -70305	1/16
PC-A414	•	•	•	•	•	1/2	13/4	MBC-A40614	-70406	1/8
PC-A514		•				5/8	13/4	—	—	3/16
PC-A620	•	•	•	•	•	3/4	21/2	MBC-A61020	-120610	3/8
PC-A824	•	•	•	•	•	1	3	MBC-A81224	-160812	13/16
PC-A826						1	31/4	—	—	7/8
PC-A830	•	•				1	33/4	—	—	1
PC-A834		•				1	41/4	—	—	1
PC-A1132	•		•	•	•	13/8	4	MBC-A111632	-201116	2
PC-A1148	•					13/8	6	—	—	—
PC-A1440	•			•	•	13/4	5	MBC-A142040	-241420	37/8
PC-A1640	•			•	•	2	5	MBC-A162040	-301620	53/8
PC-A2048	•			•	•	21/2	6	MBC-A202448	-362024	95/8
PC-A2448	•			•	•	3	6	MBC-A242448	-402424	14
PC-A2452	•			•	•	3	61/2	—	-402424	16
PC-A2864	•			•	•	31/2	8	MBC-A283264	-522832 -562832	32 —
PC-A3272	•			•	•	4	9	MBC-A323672	-643236	36
PC-A4096	•					5	12	MBC-A404896	-844048	—



# ▶ Rod Aligning Coupler & Rod Eyes

## Rod Aligning Coupler\* A Heavy Duty Problem Solver...

The CylindersNow ROD ALIGNING COUPLER (RAC) was designed to eliminate misalignment problems and to achieve longer cylinder life.

Easily threaded onto the cylinder piston rod end, the RAC, with its 10° of angular movement and 1/8" axial float, compensates for normally difficult alignment and enables faster installation of cylinders. No longer a need for oversize or oblong holes in mating members, or the shimming of components!

The RAC relieves side loading, resulting in reduced rod seal and bearing wear as well as preventing cylinder binding

caused by misalignment. In short, longer, trouble-free cylinder life is achieved!

The CylindersNow ROD ALIGNING COUPLER has the capability of transmitting push or pull forces equally well. A true HEAVY DUTY accessory, the RAC can be used on cylinders at full rated operating pressure with complete confidence. See Load Rating in chart below.

- 10° total angular movement
- Two wrench flats each end
- 1/8" total axial float
- Made from high yield carbon steel
- Lubricated at factory with long wearing moly/petroleum lubricant.

\*To be used on fixed mount cylinders only.

## Rod Aligning Coupler

PART NUMBER	A	B	C	DD	DE	F	G	H	K	KK THREAD	RATED LOAD POUNDS	WT. IN LBS.
RAC-0044	3/4	19/16	2	1/2	5/8	5/8	11/16	3/4	15/32	7/16-20	3,250	5/8
RAC-0050	3/4	19/16	2	1/2	5/8	5/8	11/16	3/4	15/32	1/2-20	4,450	5/8
RAC-0062	11/8	21/8	25/16	7/8	11/8	1	15/16	11/4	9/16	5/8-18	7,150	19/16
RAC-0075	11/8	21/8	25/16	7/8	11/8	1	15/16	11/4	9/16	3/4-16	9,050	19/16
RAC-0100	15/8	23/4	31/8	11/8	11/4	11/4	21/16	11/2	5/8	1-14	19,425	4
RAC-0125	2	31/2	4	11/4	111/16	11/2	21/2	2	13/16	11/4-12	30,825	8
RAC-0150	21/4	4	43/8	11/2	115/16	13/4	23/4	21/4	15/16	11/2-12	45,750	111/2
RAC-0187	3	5	55/8	115/16	25/8	21/4	33/8	3	17/16	17/8-12	67,550	211/2

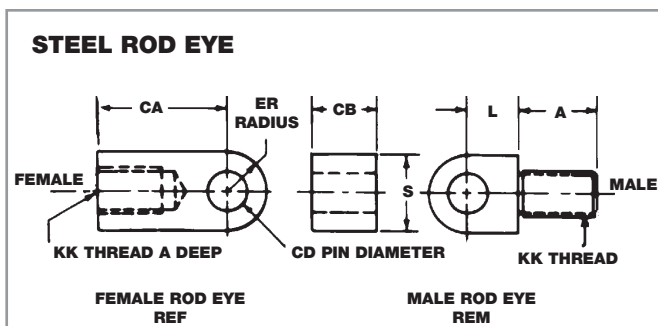
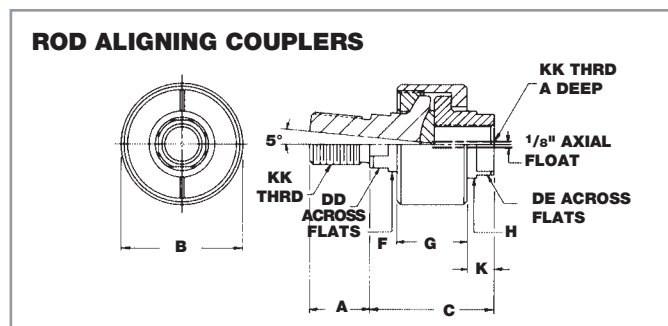

## Rod Eyes

MALE ROD EYE	FEMALE ROD EYE	SERIES								KK THD.	A	CA	CB	CD	ER	L	S	STYLE II or IV RODS	MATCHING CLEVIS MOUNTING BRACKETS	WT. IN LBS.
		A	AA	C20	CLA	MA	CLH	HH	MH											
—	REF-40203				•					1/4-28	5/16	11/16	3/8	1/4	1/4	—	1/2	—	—	1/16
—	REF-50304				•					5/16-24	3/8	13/16	1/2	5/16	5/16	—	5/8	—	—	3/32
REM-50305	REF-50305	•							•	5/16-24	3/4	11/4	5/8	3/8	3/8	1/2	3/4	1/2	MBC-A30510	—
—	REF-70305		•							7/16-20	5/8	11/4	5/8	3/8	3/8	—	3/4	—	—	5/32
REM-70305	REF-70305	•							•	7/16-20	3/4	11/4	5/8	3/8	3/8	1/2	3/4	11/16	MBC-A30510	—
REM-70406	REF-70406	•							•	7/16-20	3/4	11/2	3/4	1/2	1/2	5/8	1	5/8	MBC-A40614 832-40614	5/16
REM-80406	REF-80406	•	•							1/2-20	3/4	11/2	3/4	1/2	1/2	5/8	1	5/8	MBC-A40614	—
—	REF-100408			•						5/8-18	1	13/4	1	1/2	1/2	—	1	—	—	5/16
REM-120610	REF-120610	•	•						•	3/4-16	11/8	21/16	11/4	3/4	3/4	7/8	11/2	1	MBC-A61020 832-61020	11/8
REM-160812	REF-160812	•	•						•	1-14	15/8	213/16	11/2	1	1	11/8	2	13/8	MBC-A81224 832-81224	25/16
REM-201116	REF-201116	•	•						•	11/4-12	2	37/16	2	13/8	13/8	15/8	23/4	13/4	MBC-A111632	59/16
—	REF-221116			•						13/8-12	2	37/16	2	13/8	13/8	—	23/4	—	—	51/4
REM-241420	REF-241420	•							•	11/2-12	21/4	4	21/2	13/4	13/4	2	31/2	2	MBC-A142040	101/2
REM-281420	REF-281420	•							•	13/4-12	21/4	4	21/2	13/4	13/4	2	31/2	2	MBC-A142040	—
REM-301620	REF-301620	•							•	17/8-12	3	5	21/2	2	2	21/4	4	21/2	MBC-A162040	14
REM-362024	REF-362024	•							•	21/4-12	31/2	513/16	3	21/2	21/2	23/4	5	3	MBC-A202448	26
REM-402424	REF-402424	•							•	21/2-12	31/2	61/8	3	3	23/4	41/4	51/2	31/2	MBC-A242448	28
REM-482428	REF-482428	•							•	3-12	4	7	31/2	3	3	41/4	6	4	MBC-A242856	31
REM-522832	REF-522832	•							•	31/4-12	41/2	75/8	4	31/2	31/2	5	7	41/2	MBC-A283264	61
REM-562832	REF-562832	•							•	31/2-12	5	83/8	4	31/2	31/2	5	7	5	MBC-A283264	65
REM-643236	REF-643236	•							•	4-12	51/2	9	41/2	4	4	53/4	8	51/2	MBC-A323672	75
REM-844048	REF-844048	•							•	51/4-12	7	111/4	6	5	5	51/4	10	7	MBC-A404896	—

## **CylindersNow Cylinders are Better Cylinders!**

**The performance you expect from a quality cylinder**

- ▶ **Longer lifetime of service**
- ▶ **Minimal downtime**
- ▶ **Fast and easy installation**
- ▶ **Simple, affordable repairs**
- ▶ **No special tools required to make repairs**
- ▶ **Lower operating cost**
- ▶ **More options available**

## **Our Cylinders are Designed with the End User in Mind**

### **Studded Rod End**

*(Standard, except on C20 Series)*

Sheffer's rod end design virtually eliminates rod end breakage! The rod ends of many competitive cylinders are cut from the piston rod, creating a weak point at the threads. Our studded connection routes stress factors away from this weak point, so rod-end failure is nearly impossible. Also, rod ends can be replaced without changing the entire piston rod, thereby reducing downtime and repair costs.

### **Four Full Wrench Flats**

For convenience, time and money savings during cylinder installation or replacement, CylindersNow cylinders are produced with four full wrench flats. With our design, a flat is always positioned for a good wrench hold with normal tools. Our cylinders come this way because unconventional tools and methods are often used when a wrench flat isn't convenient – possibly marring the rod surface which can damage seals and cause leaks.

### **Removable Rod Gland**

*(Not available on select small bore cylinders)*

The wiper and pressure seals on CylindersNow cylinders are encapsulated behind a removable rod gland that is bolted to the front of the cylinder. "On line" changing of seals is fast and easy using normal tools, without disturbing

torque settings, removing the rod bearing or tearing down the cylinder. This feature dramatically increases productivity by reducing downtime and repair costs.

### **Separate Rod Bearing**

On CylindersNow cylinders, the rod bearing is a hydrodynamic "flooded bearing", which greatly reduces wear and extends part life. It's also inboard from the seals and a separate component, so if changeout is needed, the seals need not be replaced – and vice versa. No special tools are required. Moreover, the rod bearing can be removed and replaced without having to loosen tie rods or tear down the cylinder. That saves downtime, plus the cost of parts and labor.

### **Chamfered Tube Ends**

A small angle, or chamfer, is machined into the end of each CylindersNow piston tube for quick, easy and reliable repairs. If the piston and rod have been removed (to replace seals for example), when the piston is pushed back in, the chamfer physically compresses the seal into the piston like a built-in funnel. Special compression tools aren't needed during assembly and chances of seal damage are minimized. The chamfer design also prohibits extrusion of the O-ring once the tie rods are tightened. This forms a superior seal and diminishes the chance of leakage at the head and cap joint.

### **Slipper Piston Seal & Bearing**

*(Standard on all hydraulic cylinders)*

The slipper piston seal and bearing on CylindersNow cylinders are a standard option, not a cost-additive feature other manufacturers offer when their designs are inadequate. Our Teflon® based surfaces are an excellent lubricant, demonstrating a very low coefficient of friction with low heat. As the cylinder moves back and forth, the Teflon also migrates into the pores of the cylinder tube, creating an even better lubricating surface. Slipper seals and bearings – another reason CylindersNow cylinders reduce costs and downtime while increasing productivity.



# ► Conversions

## Fraction Equivalents

Fraction (inches)	Decimal (inches)	Metric (mm) (x 25.4)
1/64	.016	.4
1/32	.031	.8
3/64	.047	1.2
1/16	.062	1.6
5/64	.078	2.0
3/32	.094	2.4
7/64	.109	2.8
1/8	.125	3.2
9/64	.141	3.6
5/32	.156	4.0
11/64	.172	4.4
3/16	.187	4.7
13/64	.203	5.2
7/32	.219	5.6
15/64	.234	5.9
1/4	.250	6.3
17/64	.266	6.8
9/32	.281	7.1
19/64	.297	7.5
5/16	.312	7.9
21/64	.328	8.3
11/32	.344	8.7
23/64	.359	9.1
3/8	.375	9.5
25/64	.391	9.9
13/32	.406	10.3
27/64	.422	10.7
7/16	.437	11.1
29/64	.453	11.5
15/32	.469	11.9
31/64	.484	12.3
1/2	.500	12.7

Fraction (inches)	Decimal (inches)	Metric (mm) (x 25.4)
33/64	.516	13.1
17/32	.531	13.5
35/64	.547	13.9
9/16	.562	14.3
37/64	.578	14.7
19/32	.594	15.1
39/64	.609	15.5
5/8	.625	15.9
41/64	.641	16.3
21/32	.656	16.7
43/64	.672	17.1
11/16	.687	17.4
45/64	.703	17.9
23/32	.719	18.3
47/64	.734	18.6
3/4	.750	19.0
49/64	.766	19.5
25/32	.781	19.8
51/64	.797	20.2
13/16	.812	20.6
53/64	.828	21.0
27/32	.844	21.4
55/64	.859	21.8
7/8	.875	22.2
57/64	.891	22.6
29/32	.906	23.0
59/64	.922	23.4
15/16	.937	23.8
61/64	.953	24.2
31/32	.969	24.6
63/64	.984	25.0
1	1.000	25.4

## Temperature Equivalents

F°	C°
-30	-34.4
-20	-28.9
-10	-23.3
0	-17.8
10	-12.2
20	-6.7
30	-1.1
40	4.4
50	10.0
60	15.6
70	21.1
80	26.7
90	32.2
100	37.8
110	43.3
120	48.9
130	54.4
140	60.0
150	65.6
160	71.1
170	76.7
180	82.2
190	87.8
200	93.3
210	98.9
220	104.4
230	110.0
240	115.6
250	121.1
260	126.7

C°	F°
-30	-22
-20	-4
-10	14
0	32
5	41
10	50
15	59
20	68
25	77
30	86
35	95
40	104
45	113
50	122
55	131
60	140
65	149
70	158
75	167
80	176
85	185
90	194
95	203
100	212
105	221
110	230
115	239
120	248
125	257
130	266

$$C^{\circ} = (F^{\circ} - 32) \div 1.8$$

$$F^{\circ} = C^{\circ} \times 1.8 + 32$$

# ► Conversions

## Pressure Conversions

PSI	Kg/cm <sup>2</sup>	Bars
60	4.2	4.1
70	4.9	4.8
80	5.6	5.5
90	6.3	6.2
100	7.0	6.9
150	10.5	10.3
200	14.0	13.8
250	17.6	17.2
300	21.1	20.7
350	24.6	24.1
400	28.1	27.6
450	31.6	31.0
500	35.1	34.4
550	38.7	37.9
600	42.2	41.3
650	45.7	44.8
700	49.2	48.2
750	52.7	51.7
800	56.2	55.1
850	59.8	58.6
900	63.3	62.0
950	66.8	65.5
1000	70.3	68.9
1500	105.5	103.4
2000	140.6	137.8
2500	175.8	172.3
3000	210.9	206.7
3500	246.1	241.2
4000	281.2	275.6
4500	316.4	310.1
5000	351.5	344.5

Kg/cm<sup>2</sup> = PSI x .0703  
 Bars = PSI x .0689

Kg/cm <sup>2</sup>	PSI	Bars
4	56.9	3.9
5	71.1	4.9
6	85.3	5.9
7	99.5	6.9
8	113.8	7.8
9	128.0	8.8
10	142.2	9.8
20	284.4	19.6
30	426.6	29.4
40	568.8	39.2
50	711.0	49.0
60	853.2	58.8
70	995.4	68.6
80	1137.6	78.4
90	1279.8	88.2
100	1422.0	98.0
150	2133.0	147.0
200	2844.0	196.0
250	3555.0	245.0
300	4266.0	294.0
350	4977.0	343.0
400	5688.0	392.0

PSI = Kg/cm<sup>2</sup> x 14.22  
 Bars = Kg/cm<sup>2</sup> x .98

## Distance Conversions

Inches	cm	mm
1	2.5	25.4
2	5.1	50.8
3	7.6	76.2
4	10.2	101.6
5	12.7	127.0
6	15.2	152.4
7	17.8	177.8
8	20.3	203.2
9	22.9	228.6
10	25.4	254.0
15	38.1	381.0
20	50.8	508.0
25	63.5	635.0
30	76.2	762.0
35	88.9	889.0
40	101.6	1016.0
45	114.3	1143.0
50	127.0	1270.0
55	139.7	1397.0
60	152.4	1524.0
65	165.1	1651.0
70	177.8	1778.0
75	190.5	1905.0
80	203.2	2032.0
85	215.9	2159.0
90	228.6	2286.0
95	241.3	2413.0
100	254.0	2540.0

cm = in. x 2.54  
 mm = in. x 25.4

cm	Inches
1	.4
2	.8
3	1.2
4	1.6
5	2.0
6	2.4
7	2.8
8	3.1
9	3.5
10	3.9
20	7.9
30	11.8
40	15.8
50	19.7
60	23.6
70	27.6
80	31.5
90	35.5
100	39.4
110	43.3
120	47.3
130	51.2
140	55.2
150	59.1
160	63.0
170	67.0
180	70.9
190	74.9
200	78.8
210	82.7
220	86.7
230	90.6
240	94.6
250	98.5
260	102.4

in. = cm x .394